



# KM-1900S\_J(3)

## STACKABLE CRESCENT CUBER



KM-1900S\_J(3)  
02/13/18  
Item # 13190

Item #: \_\_\_\_\_  
 Project: \_\_\_\_\_  
 Qty: \_\_\_\_\_  
 AIA#: \_\_\_\_\_

**W x D x H**  
48" x 27<sup>3/8</sup>" x 36<sup>7/16</sup>"

Shipping Dimensions  
51<sup>3/4</sup>" x 33" x 43"

**KM Edge DESIGN**

**KM-1900SAJ** ★

Air-Cooled 1 Phase  
Shown on optional bin: B-900

**KM-1900SWJ**

Water-Cooled 1 Phase

**KM-1900SRJ** ★

Remote Air-Cooled 1 Phase

**KM-1900SAJ3** ★

Air-Cooled 3 Phase

**KM-1900SWJ3**

Water-Cooled 3 Phase

**KM-1900SRJ3** ★

Remote Air-Cooled 3 Phase



## Features

▶ Individual crescent cube

▶ Stainless steel evaporator

▶ CycleSaver™ design

- Up to 1933 lbs. of ice production per 24 hours
- Stackable for 3866 lbs. per 24 hours ice production in the same floor space
- Durable stainless steel exterior
- Protected by H-Guard Plus Antimicrobial Agent
- EverCheck™ alert system
- R-404A Refrigerant

Available on Bins:

**B-800**    **B-1150SS**    **B-1500SS**    *Top kit may be required.*  
**B-900**    **B-1300SS**    **B-1650SS**    *See Bin Spec Sheets.*

**Warranty:**

Valid in United States, Canada, Puerto Rico and U.S. Territories. Contact factory for warranty in other countries.



	Condenser	Model	ICE PRODUCTION		WATER USAGE			ELECTRICAL						
			Air / Water Temp Lbs. per 24 hours 70°/50°F	90°/70°F	Potable Gal. per 100 lbs. 90°/70°F	Condenser Gal. per 100 lbs. 90°/70°F	kWh Used per 100 lbs. 90°/70°F	Max. Fuse Size or HACR Circuit Breaker	Amperage	Voltage	Circuit Wires (including ground)	Heat Rejection BTU/hr.	Refrigerant Charge Amount	Net / Ship Weight (lbs.)
1 Phase	Air	KM-1900SAJ	1875	1675	19.0	N/A	3.90	30A	14.5A	208-230V/60/1	4*	21,200	4 lb. 10.1 oz.	390 / 415
	Water	KM-1900SWJ	1880	1875	21.0	85	3.20	30A	15.8A	208-230V/60/1	4*	21,500	3 lb. 1.4 oz.	390 / 415
	Remote	KM-1900SRJ	1933	1700	19.0	N/A	3.90	30A	15.9A	208-230V/60/1	4*	24,200	13 lb. 12.5 oz. 21 lbs. 7.9 oz. <sup>1</sup>	390 / 415
3 Phase	Air	KM-1900SAJ3	1865	1675	19.0	N/A	3.90	20A	8.9A	208-230V/60/3	4	20,900	4 lb. 10.1 oz.	390 / 415
	Water	KM-1900SWJ3	1880	1875	21.0	85	3.20	20A	8.9A	208-230V/60/3	4	21,900	3 lb. 1.4 oz.	390 / 415
	Remote	KM-1900SRJ3	1933	1700	19.0	N/A	3.90	20A	13.5A	208-230V/60/3	4	20,700	13 lb. 12.5 oz. 21 lbs. 7.9 oz. <sup>1</sup>	390 / 415

\*If neutral is not available, transformer kit (HS-5030) is required. Refer to Instruction Manual for installation and electrical requirements.

<sup>1</sup>with condenser  
Power cord not included

### KM Edge Cube Dimensions\*

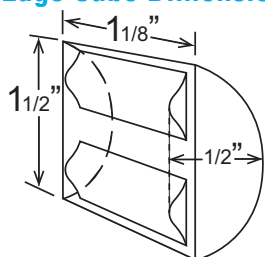

\* approximate size in inches, image not to scale

### Operating Limits

- Ambient Temp Range 45 - 100°F
- Water Temp Range 45 - 90°F
- Water Pressure 10 - 113 PSIG
- Voltage Range 187 - 253V

### Service

- Panels easily removed and all components accessible for service.
- Allow 6" (15 cm) clearance at rear, sides, and top for proper air circulation and ease of maintenance/service.

### Plumbing

- Icemaker Water Supply Line: Min. 3/8" Nominal ID Copper Water Tubing or Equivalent
- Icemaker Drain Line: Min. 3/4" Nominal ID Hard Pipe or Equivalent **Water-Cooled Model (Lines Must Be Independent of Icemaker)**
- Condenser Water Supply Line: Min. 3/8" Nominal ID Copper Water Tubing or Equivalent
- Condenser Drain/Return Line: Min. 3/8" Nominal ID Hard Pipe (open drain system) or Copper Water Tubing (closed loop system) or Equivalent

### Water Filter

Please refer to water filter spec sheet for recommended configurations.

Hoshizaki reserves the right to change specifications without notice.



# KM-1900S\_J(3)

## STACKABLE CRESCENT CUBER



KM-1900S\_J(3)  
02/13/18  
Item # 13190

FRONT VIEW

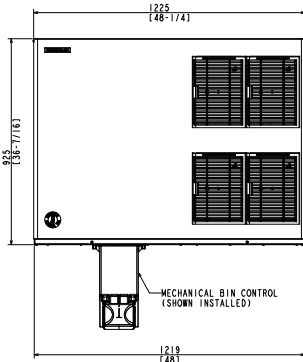

AIR-COOLED

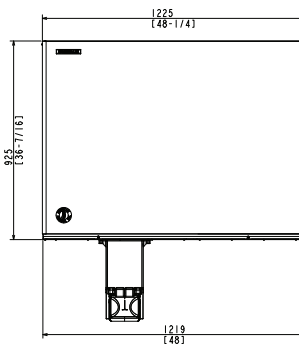

WATER-COOLED

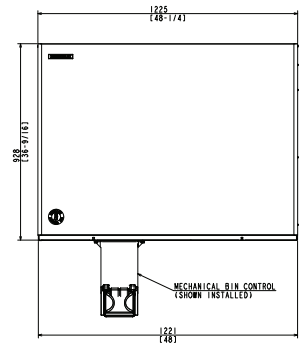

REMOTE AIR-COOLED

SIDE VIEW

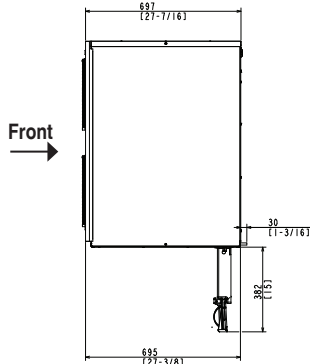

AIR-COOLED

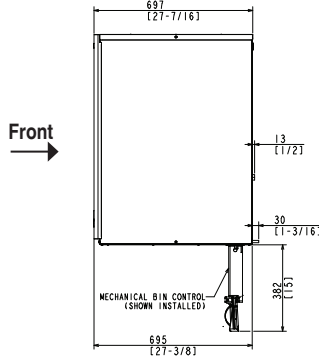

WATER-COOLED

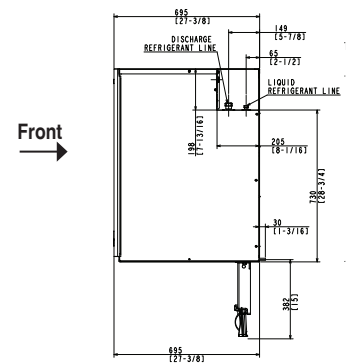

REMOTE AIR-COOLED

REAR VIEW

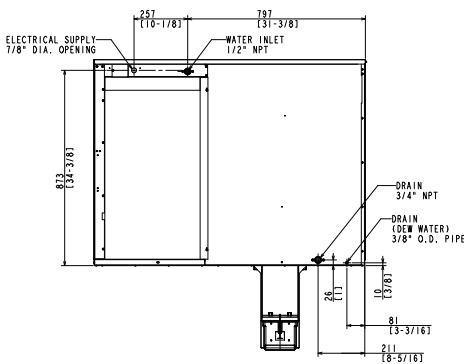

AIR-COOLED

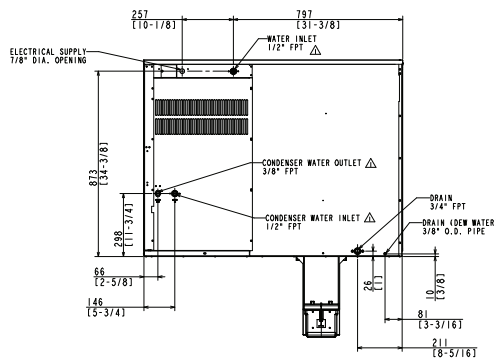

WATER-COOLED

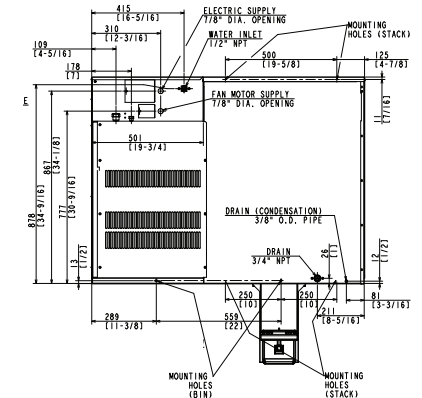

REMOTE AIR-COOLED

BOTTOM VIEW

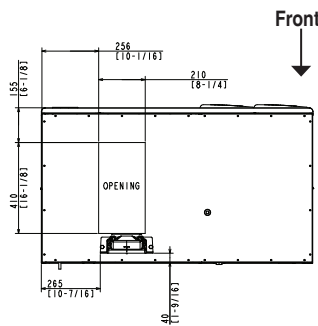

AIR-COOLED  
WATER-COOLED

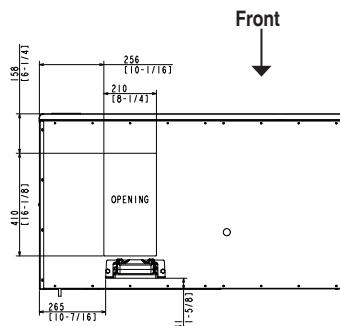

REMOTE AIR-COOLED

**URC-22F Remote Condenser (Sold Separately)**  
(W x D x H) 46 3/8 X 14 1/16 X 40 1/2  
For Use with KM-1900SRJ(3)

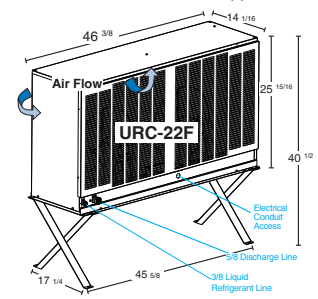

**Pre-Charged Tubing Kits**

(Sold Separately)  
20' R404-20610  
35' R404-35610  
55' R404-55610



Voltage supply for the URC Remote Condenser is supplied from the Ice Maker. No additional circuit is required.