

# ET Series by

## MULTI-USE UNDERCOUNTER DISHWASHERS



*Perfect for Restaurants,  
Delicatessens & Fast  
Food Operations*

*An Industrial  
Design Machine  
for Commercial  
Application*

*FINALLY, an undercounter  
that offers kitchenware results,  
in a glass washing machine*



Process over 200 trays per hour.  
Great for small bed nursing  
homes and day care facilities

When space demands a small dishmachine, don't sacrifice quality or results.  
*Ask for one of the ET-AF UNDERCOUNTERS.*

At American Dish Service, Quality People,  
Designs, and Products have been the foundations  
of our organization for over 45 years.

[www.americandish.com](http://www.americandish.com)

  
**American Dish Service**  
Manufacturers of Ware Washing Equipment

Toll Free

Phone

Fax

900 Blake Street Edwardsville, KS 66111-3820 (800) 922-2178 (913) 422-3700 (913) 422-6630

# ET Series

MULTI-USE UNDERCOUNTER DISHWASHERS

ET... The Dishmachine of choice, when space is a concern. You will **NEVER AGAIN** have to sacrifice production or results.

- 1 1/2 HP Wash and Rinse Pump
- Prime Switches
- Automatic Chemical Feed
- 90 Second Complete Time Cycle
- Hinged Mounted Panel for Easy Service Access



Operate a free standing complete warewashing center in only 48" of space. To do this, combine our ET-AF Undercounter with our stainless steel table package.

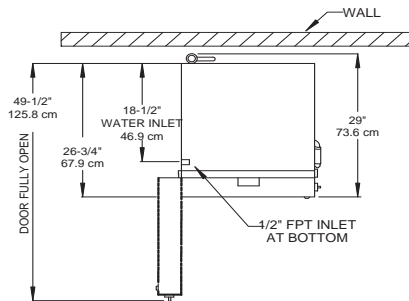

TOP VIEW

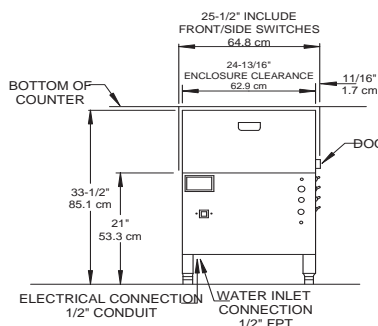

FRONT VIEW

**CAUTION:**  
Electrical and plumbing connections must be made by a qualified Service Person who will comply with all available federal, state, and local Health, Electrical, Plumbing, and Safety codes.

\*Manufacturer reserves the right to modify these specifications in compliance with regulatory agencies and manufacturing expediency.

**NOTE:**  
All dimensions listed have a tolerance of + or - 1/8" unless otherwise noted.

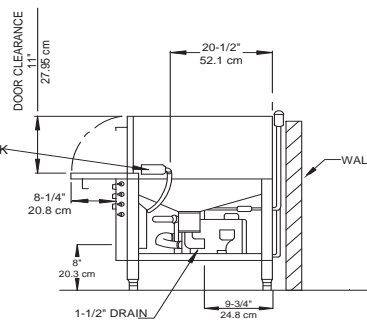

SIDE VIEW

**American Dish Service**  
Manufacturers of Ware Washing Equipment  
WWW.AMERICANDISH.COM

## ET SERIES SPECIFICATIONS

	FAMILY MODELS
	ET-AF ET-A ET-AH
NSF RATED CAPACITY (Racks/Hr.)	30 24 20
WASH TIME (Sec.)	45 60 75
RINSE TIME (Sec.)	30 45 60
DWELL (Sec.)	15 15 15
TOTAL CYCLE TIME (Sec.)	90 120 150
WATER TEMPERATURE-SUPPLY WATER	(NSF) 120 F Min. 49 C Min.
WATER CONSUMPTION (NSF RATED)	1.7 Gal's Per Cycle 6.4 Lit's Per Cycle
MOTOR RATING (PUMP)	1/2" FPT 1.5 HP
ELECTRICAL RATINGS (NEC)	115 Vac, 20amp brkr, 50/60Hz, 1Phase
Connect to Supply Source using 10-12 AWG copper wires using non-time delay fuse of 20 amp rating or 20 amp circuit breaker.	
RACK SIZE	19.75" x 19.75" 50.2 cm x 50.2 cm
DOOR CLEARANCE	"M" Series: 11" x 22.25"(27.9cm x 56.5cm) "3" Series: 14" x 22.25"(35.8cm x 57cm)
WATER INLET	1/2" FPT
DRAIN SIZE	1 1/2" FPT
HEIGHT OF STANDARD ET	Min 33.5"-Max 34.5" 85.1 to 87.6 cm
HEIGHT OF ET-AF-3	Min 36.5"-Max 37.5" 92.7 to 95.2 cm
WIDTH (Overall)	25.5"
DEPTH (Overall)	64.8 cm 29"
SHIPPING WEIGHT	"M" Series: 250 Pounds (113.4 kg) "3" Series: 258 Pounds (117.0 kg)
SHIPPING DIMENSIONS	"M" Series: 36"L x 36"W x 41"H "3" Series: 36"L x 36"W x 44"H

Effective: 4/16

Copyright 4/16

**WARNING:** Cancer and Reproductive Harm - [www.P65Warnings.ca.gov](http://www.P65Warnings.ca.gov)

900 Blake Street Edwardsville, KS 66111-3820 (800) 922-2178 (913) 422-3700 (913) 422-6630

Toll Free

Phone

Fax